



SEBO AIRBELT E

MADE IN GERMANY

# OWNER'S MANUAL

For Household Use Only



# TABLE OF CONTENTS

<b>Technical Details</b> .....	<b>2</b>
<b>How To Contact SEBO</b> .....	<b>2</b>
<b>Important Safety Instructions</b> .....	<b>3</b>
<b>Special AIRBELT E Product Features</b> .....	<b>4</b>
<b>AIRBELT E1 Kombi &amp; E2 Turbo Features</b> .....	<b>4</b>
<b>AIRBELT E3 Premium Features</b> .....	<b>5</b>
<b>Optional Attachments, Accessories, Bags and Filters</b> .....	<b>5</b>
<b>Standard Features of All SEBO Vacuums</b> .....	<b>6</b>
<b>Identification of Parts</b> .....	<b>7</b>
Standard Attachments .....	7
Brushes and Heads .....	7
<b>Assembly</b> .....	<b>7</b>
<b>Operating Instructions</b> .....	<b>8</b>
Starting the Machine .....	8
Suction Control .....	8
Operating the Machine .....	8
<b>Additional Operating Instructions for E3 Premium with Power Head</b> .....	<b>9</b>
Starting the Machine and Suction Control .....	9
Operating the Machine .....	9
Using the Telescopic Tube, Hose & Attachments .....	10
<b>Use and Maintenance of Brushes and Heads</b> .....	<b>10</b>
The Parquet Brush.....	10
The Kombi Nozzle.....	10
The Turbo Nozzle.....	10
<b>Vacuum Maintenance</b> .....	<b>11</b>
Changing the Filter Bag .....	11
Changing the Pre-motor Filter .....	11
Changing the Exhaust Microfilter .....	11
Changing the AIRBELT .....	12
<b>Clog Removal</b> .....	<b>13</b>
Clogs in the Head or Brush .....	13
Clogs in the Telescopic Tube .....	13
Clogs in the Hose .....	13
Clogs in Entrance to Filter Bag .....	13
<b>Trouble-Shooting Guide</b> .....	<b>14</b>
<b>AIRBELT E1 Kombi &amp; E2 Turbo Schematic and Part Numbers</b> .....	<b>15</b>
<b>AIRBELT E3 Premium Schematic and Part Numbers</b> .....	<b>16</b>

## TECHNICAL DETAILS

Vacuum motor	1200 watts
Filter bag capacity	.92 gallons
Body weight	11.4 lbs
Motor protection	Thermal cut-out
Cord length	25 feet
Range	37 feet

Technical details may be subject to change.

## HOW TO CONTACT SEBO

### To contact SEBO in the United States of America:

SEBO America, LLC  
 Telephone: (800) 334-6614  
 Fax: (303) 792-9196  
 Website: [www.sebo.us](http://www.sebo.us)

### To contact SEBO in Canada:

Floor Care Equipment, Ltd.  
 Telephone: (800) 661-8687  
 Fax: (800) 270-4807  
 Website: [www.sebocanada.ca](http://www.sebocanada.ca)

For Warranty coverage information please refer to your Warranty Card included with your SEBO vacuum cleaner.

# IMPORTANT SAFETY INSTRUCTIONS



## **READ ALL INSTRUCTIONS BEFORE USING THIS MACHINE**

### **When using an electrical appliance, basic precautions must always be followed.**

To reduce the risk of electric shock, this vacuum cleaner has a polarized plug; one blade is wider than the other. This plug will fit in a polarized outlet only one way. If the plug does not fit fully in the outlet, reverse the plug. If it still does not fit, contact a qualified electrician to install the proper outlet. Do not change the plug in any way. Connect only to the outlet type specified on the serial number plate underneath the machine.

### **SAVE THESE INSTRUCTIONS.**

## **WARNING: To reduce the risk of fire, electric shock, or injury:**

1. Do not leave vacuum while plugged in. Unplug from outlet when not in use and before servicing.
2. Do not use outdoors or on wet surfaces.
3. Do not use near small children or pets. Do not allow to be used as a toy. Use of this product by children should always be supervised by an adult.
4. Use only as described in this manual. Use only manufacturer-recommended attachments.
5. Do not use with a damaged cord or plug. If vacuum is not working as it should, has been dropped, damaged, left outdoors, or dropped into water, take it to a SEBO service center.
6. Do not pull or carry by cord, use cord as a handle, close a door on cord, or pull cord around sharp edges or corners. Do not run vacuum over cord. Keep cord away from heated surfaces.
7. Do not unplug by pulling on cord. To unplug, grasp the plug – not the cord.
8. Do not use outlets above counters to plug in vacuum – damage to items in the surrounding area could occur.
9. Always carry the vacuum over steps and sills.
10. Do not handle plug or vacuum handle with wet hands.
11. Do not put any object into vacuum openings. Do not use machine with any openings blocked. Keep openings free of lint, hair, and anything that may reduce air flow.
12. Do not re-use filter bags or wash the filters.
13. Do not remove any screws from vacuum.
14. Do not vacuum up anything that is burning or smoking, such as cigarettes, matches, or hot ashes.
15. Do not use vacuum without filter bag and/or filters in place.
16. Turn off all machine controls before unplugging.
17. Use extra care when cleaning on stairs.
18. Do not use machine to vacuum up flammable or combustible liquids such as gasoline or use in areas where they may be present.
19. Machines can cause a fire when operated near flammable vapors or materials. Do not operate this vacuum near flammable fluids, dust or vapors.
20. Maintenance and repairs must be done by authorized personnel.
21. Use only original SEBO replacement parts.
22. Do not use vacuum as a step.
23. If vacuum is used on plush carpet or carpet with thick padding, do not leave machine standing in one place with machine turned on.
24. While the vacuum is in use, the power cord should be unwound from the cable reel at least two thirds of its length. Hold plug when rewinding onto the cord reel. Do not allow plug to whip while rewinding.
25. Keep hair, loose clothing, fingers, and all parts of body away from vacuum openings and moving parts. Do not place fingers or other body parts under vacuum unless it is unplugged.
26. Do not place the power head over rug or carpet edges.
27. The vacuum has a manual reset thermal protector. The protector is reset by switching off the vacuum. The thermal protector needs some time to cool down after switching off! Check the vacuum for air blockages or mechanical failures before switching on.
28. Store the vacuum in a dry place at room temperature. When the vacuum is not in use, you should rewind the cord onto the cord reel.
29. The E3 hose contains electrical wires. Do not use if damaged, cut, or punctured. Avoid picking up sharp objects.
30. Always unplug vacuum before connecting or disconnecting either hose or power head.
31. Use a SEBO power head only in combination with a SEBO vacuum cleaner.
32. Do not connect power head to a malfunctioning or damaged vacuum.

# SEBO AIRBELT E PRODUCT FEATURES

## Bag Full or Clog Indicator & Auto Shut Off –

The warning indicator will show orange and the machine will automatically shut off when it senses a full bag, a clog in the airflow pathway, or an excessively dirty micro filter. If the vacuum's airflow pathway becomes restricted due to a full bag or the existence of a clog, the warning indicator located on the top of the canister will show orange. If the user ignores this warning, the suction motor will heat up due to the lack of cooling provided by the airflow. Once the motor reaches a certain temperature it will shut off to protect itself from damage. The user should turn the switch off, unplug the machine and immediately insert a new bag or remove the clog (to remove a clog, refer to the Clog Removal section on page 13). After approximately 30 minutes, the motor will have cooled and the vacuum can be restarted. If the airflow is still restricted, the indicator will again show orange and the machine will shut off. This feature prevents damage to the motor due to overheating.



## Shock Absorber Provides Furniture and Wall Protection –

The patented "AIRBELT" bumper that surrounds the E canisters acts as a protective barrier. The soft foam bumper with its durable cover protects furniture, walls and the vacuum itself from damage during use. The bumper also diffuses exhaust air, which contributes to its ultra-quiet performance.



**Large Operating Range –** A 37-foot operating range saves time because it minimizes the number of electrical outlets needed during use.

**Quick-release Connections –** The AIRBELT E models allow for quick and convenient connection of telescopic tubes, power brush heads, accessory cleaning heads and on-board tools.

**Comfortable Ergonomic Handle –** The AIRBELT handles are ergonomically designed and positioned to reduce wrist and arm fatigue. For extra comfort, an additional swivel is built into the handle-to-hose connection.

**Mid-sized Canister Vacuum –** The AIRBELT E models are considered mid-size canister vacuums, which means they are smaller, more compact machines that offer three full-size on-board tools and a large filter bag with a capacity of .92 gallons. The large capacity filter bag is economical because fewer bag changes are needed. An indicator window turns orange when the filter bag needs to be replaced, and closing its built-in hygiene cap prevents dust from escaping during bag removal and disposal.



**Three Protective, Rubber-coated Wheels, mounted on steel axles –** The superb rubber-coated castor-wheels glide easily and gently over all floor types, providing exceptional maneuverability and protection of floor surfaces.



**Flat-to-the-floor 3-1/2" Profile –** A low cleaning-head profile makes reaching under furniture and beds easy!

**Convenient Parking and Storage Aids –** After the work is done, the suction hose with telescopic tube and parquet brush, turbo head or Kombi Nozzle can be firmly stored on the canister's underside or backside housing.

**Three Full-size On-board Tools –** The vacuum comes standard with a crevice tool, dusting brush and upholstery nozzle. The dusting brush is mounted on the telescopic tube, and the crevice and upholstery nozzles are on the canister. Many optional accessories are also available.

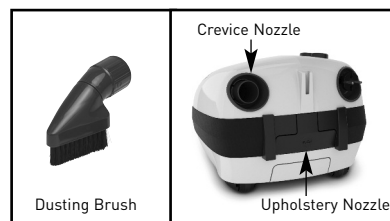

## AIRBELT E1 Kombi and E2 Turbo

The SEBO AIRBELT E1 Kombi and E2 Turbo are straight-suction vacuums. As a result, they differ from the AIRBELT E3 Premium in the following two ways:

**Variable Power Control on Canister Body –** Because the AIRBELT E1 Kombi and E2 Turbo do not have an electrified hose and telescopic tube, the variable power control switch is located on the canister body, not the handle.



**Can Not Use a Power Brush –** The AIRBELT E1 Kombi and E2 Turbo do not have an electrified telescopic tube and hose; therefore, they do not accommodate an electrified power head. Instead, the E1 Kombi model comes standard with a Kombi Nozzle for rugs and carpets and the E2 Turbo comes standard with a Turbo Nozzle, an air-driven brush head for cleaning rugs and carpet and a Parquet Brush for cleaning hard floors.

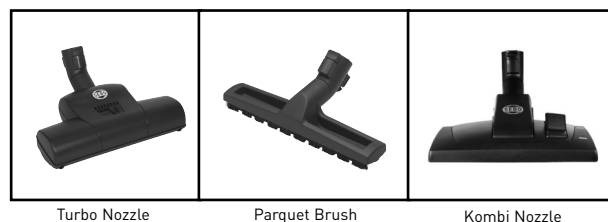

The E1 Kombi Arctic White comes standard with the Kombi Nozzle.

The E2 Turbo Dark Blue comes standard with the Turbo Nozzle and the Parquet brush.

# AIRBELT E3 Premium

## Designed for All Floor Surfaces. AIRBELT E3 Premium:

The AIRBELT E3 has an electrified hose and telescopic tube designed to accommodate the commercial-quality ET-1 power head. The ET-1 power head is designed to provide thorough brushing for optimal cleaning of carpets.

**Both Carpet and Hard Floor Cleaning** – With a power brush to clean carpets and a parquet brush to clean hard floors, the AIRBELT E3 provides all the flexibility needed to care for a variety of floor surfaces. The parquet brush comes standard.

**High-quality Telescopic Tube and Hose** – On the E3, the power cord is built inside the telescopic tube and suction hose. This eliminates unsightly external wires and enables unobstructed and convenient handle height adjustment.

**Variable Power Control on Handle** – The vacuum's suction power can be adjusted from 0 to 1,200 watts by a slider switch conveniently located on the handle.



**Powerful Vacuum Motors Provide Excellent Cleaning** – The canister suction motor is 1,200 watts, and the power head motor is 175 watts (ET-1), for a total of 1,375 watts.

## The SEBO ET-1 (12" wide, 10 1/2" cleaning width) –

This power head delivers cleaning flexibility because its brush action aggressively cleans carpeting, and the brush may be switched off to clean hard floors and delicate rugs. The steering ability of the swivel neck helps to easily clean around obstacles, and its L-shaped head provides maneuverability around furniture and under cabinets. It also has brush height and brush wear warning lights.



## Brush Obstruction Light & Auto Shut Off –

If an obstruction becomes jammed in the brush roller, a red brush-warning light will quickly flash, the brush roller will immediately stop spinning and the vacuum will shut off. The user should turn the power switch off, unplug the machine, and immediately remove the obstruction. If the user restarts the machine without removing the obstruction, the power head will again shut off and the red light will flash. This prevents the belt from breaking and protects the motor and carpet from damage.



## Incorrect Height Setting or Brush Deterioration Light –

To ensure optimum cleaning at all times, a red brush-warning light will illuminate, to indicate when the brush height is set too high for effective cleaning or when the brush roller should be replaced due to excessive wear.

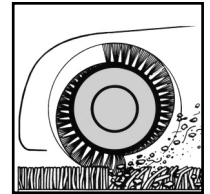

## OPTIONAL ATTACHMENTS, ACCESSORIES, BAGS & FILTERS

In addition to the standard on-board tools, a variety of optional attachments are available. The nine-foot extension hose (extends suction hoses) and the 20-inch extension tube are very popular because they create useful tools for cleaning stairs and out-of-reach areas. These two items are sold separately or as part of multiple item attachment kits. Another popular attachment is the hand held turbo brush for removing pet hair from upholstery.

SEBO filter bags can be purchased in boxes of eight and filters are sold separately. Also, bags and filters can be purchased together in model-specific kits called "Service Boxes." SEBO bags, filters and accessories are reasonably priced and widely available.

To create a fresh scent while vacuuming, "SEBO FRESH" is available. To use, deposit a scented stick in the filter bag.

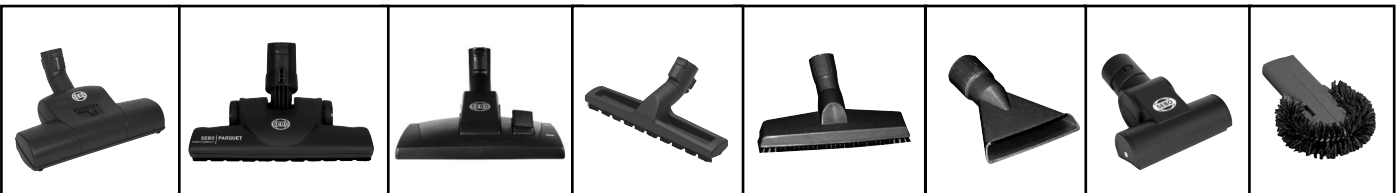

Turbo Nozzle  
Part #6780GS

Premium Parquet Nozzle  
Part #7200GS

Kombi Nozzle  
Part #1397GS

Parquet Brush  
Part #6391DA

Wall & Floor Brush  
Part #1325GS

Flat Upholstery  
Nozzle  
Part #1090GS

Hand-held Turbo  
Brush  
Part #6179GS

Radiator Brush  
Part #1496GS

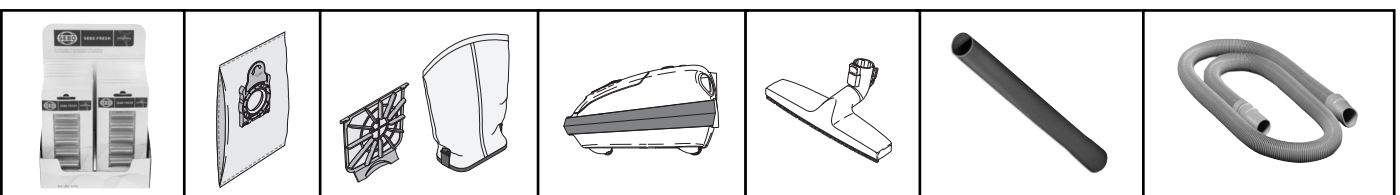

SEBO FRESH  
Part #0496AM

E Filter Bags  
Part #8300AM

E Filter Box  
includes a pre-motor  
filter and an exhaust micro-  
filter  
Part #8322AM

AIRBELT  
E1 Kombi, E2 Turbo,  
E3 Arctic White and Red: Part  
#8221AM01  
E3 Black: Part #8221AM07

Standard Brush  
Part #8118ER

20-inch Extension Tube  
Part #1084GS

9-foot Extension Hose  
Part #1495AM

# STANDARD FEATURES OF ALL SEBO VACUUMS

## SEBO'S FILTRATION SYSTEM:

**Bags are Better!** – Top-fill, three- and four-layer bags are an integral part of SEBO's filtration system because they hold virtually all dirt captured by the vacuum, which improves the effectiveness and useful life of the microfilters. They also ensure continuously strong suction because dirt enters from the top, deposits at the bottom, accumulates upward, and air exits through the sides, which allows unimpeded airflow as they fill to capacity. And they can be sealed when full, so no dust can escape into the air during bag removal and disposal.



In contrast, without bags to hold nearly all the captured dirt, the microfilters on bagless vacuums quickly clog from excessive dirt build-up and must be replaced often, or a loss of suction and cleaning effectiveness will occur. In addition, dust and other allergens become airborne when emptying bagless dirt containers. Lastly, bagless vacuum microfilters are expensive, usually costing more than a multi-year supply of SEBO filter bags.

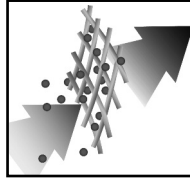

**S-class Exhaust Microfilters** – S-class Exhaust Microfilters (S = "Schwebstoff" = airborne particles) are made from electrostatically charged micro-fiber material, which attracts and captures dust particles from the airflow of the vacuum after it passes over the motor to cool it. This means that exhaust air is cleaned to the highest level. The S-class Standard requires filters to absorb greater than 99.9% of particles down to 0.3 microns in diameter. For comparison, 100 microns is the diameter of a human hair. Their advantages are a relatively open texture that allows smoother airflow for better suction performance, a longer life expectancy, and they cost less than HEPA filters

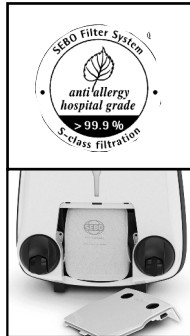

**Pre-motor Filters** - Pre-motor filters clean suction air after it passes through the filter bag, but before it passes over the vacuum motor. Cooling the motor with super-clean air increases motor life and reduces the possibility of maintenance, even after many years of use.

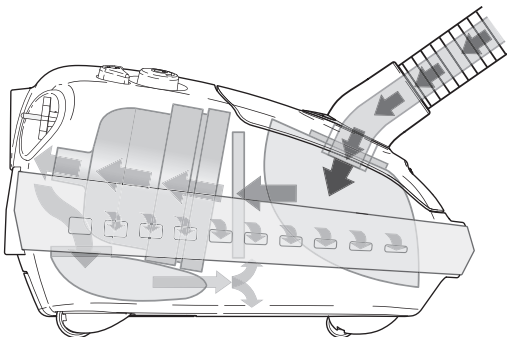

**Designed and Manufactured in Germany** – Legendary quality, reliability and performance make SEBO vacuums the choice of cleaning professionals throughout the world.

**Excellent for Users With Allergies or Asthma** – The British Allergy Foundation recommends SEBO filters.

**Tightly Sealed Vacuums Ensure Effective Filtration** – Dirty air, which flows through a vacuum, can only be filtered completely if it does not escape into the room through seams or seals in the machine. This is why all SEBO vacuums have tight seals throughout. Many vacuum companies with high-filtration claims are actually quoting specifications made by the manufacturer of the filter material, as measured in the laboratory, not the filtration effectiveness of the vacuum itself while operating. Whether or not dirty air can escape through leaks in the body of the machine is not considered. The filtration effectiveness of SEBO vacuums is tested while they operate.

**Save Money! SEBO Vacuums Last for Years and Extend Carpet Life!** – If properly maintained, SEBO vacuums save ordinary residential users hundreds of dollars by providing excellent performance for ten to fifteen years or more, and their deep-cleaning power-brush technology extends the life of carpets. Typical vacuums perform poorly, even when new, and usually do not last beyond two years. So six or seven "disposable vacuums" must be purchased during the average life expectancy of just one SEBO machine.

**Outstanding Warranty Coverage** – SEBO is confident about the quality of all its vacuums. Please refer to the **Warranty Card** included with your SEBO vacuum cleaner for complete warranty coverage information.

**SEBO Microfilters Ensure Continuously Strong Suction Performance** – They are also long lasting, inexpensive and easy to change in seconds.

**Changing Bags is Easy and Clean** – SEBO filter bags can be changed in just a few seconds, and a cap keeps dust sealed inside during removal and disposal.



**Effective Pet Hair Removal** – All SEBO vacuums easily remove pet hair!

# IDENTIFICATION OF PARTS

- |   |  |
|---|--|
| 1. Handle grip                          | 12. Filter bag cover                     |
| 2. Power control slider (E3 only)       | 13. Carrying handle                      |
| 3. Handle release button                | 14. Hose neck release buttons            |
| 4. Slide button                         | 15. Warning indicator                    |
| 5. Telescopic tube                      | 16. Suction opening                      |
| 6. Tool release button                  | 17. Filter bag cover release catch       |
| 7. Kombi nozzle                         | 18. Parking attachment groove            |
| 8. Hose                                 | 19. Exhaust filter cover                 |
| 9. Cable rewind button                  | 20. Exhaust filter cover release buttons |
| 10. On/off power control knob (E1 & E2) | 21. Power cable                          |
| On/off knob (E3)                        | 22. Parking attachment groove            |
| 11. Hose neck                           | 23. Crevice nozzle                       |
|   | 24. Upholstery Nozzle                    |
|   | 25. AIRBELT shock absorber               |

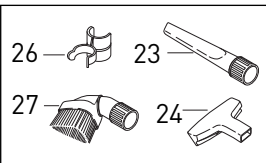

## Standard Attachments

- |                       |                        |
|-----------------------|------------------------|
| 23. Crevice nozzle    | 26. Dusting brush clip |
| 24. Upholstery nozzle | 27. Dusting brush      |

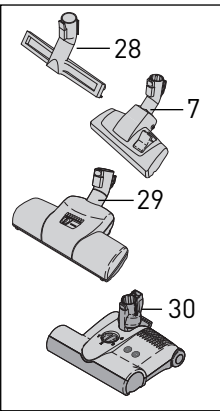

## Brushes and Heads

- |   |
|---|
| 28. Parquet brush - standard for the E3 Premiums and E2 Turbo, optional for the E1 Kombi - Part #6391DA       |
| 7. Kombi nozzle - standard for the E1 Kombi, optional for the E3 Premiums and E2 Turbo - Part #1397GS         |
| 29. Turbo nozzle - standard for the E2 Turbo, optional for the E3 Premiums and E1 Kombi - Part #6780GS        |
| 30. ET-1 Power Head - standard for E3 Premiums Part #9258AM - Arctic White; #9299AM - Red; #9981AM - Graphite |

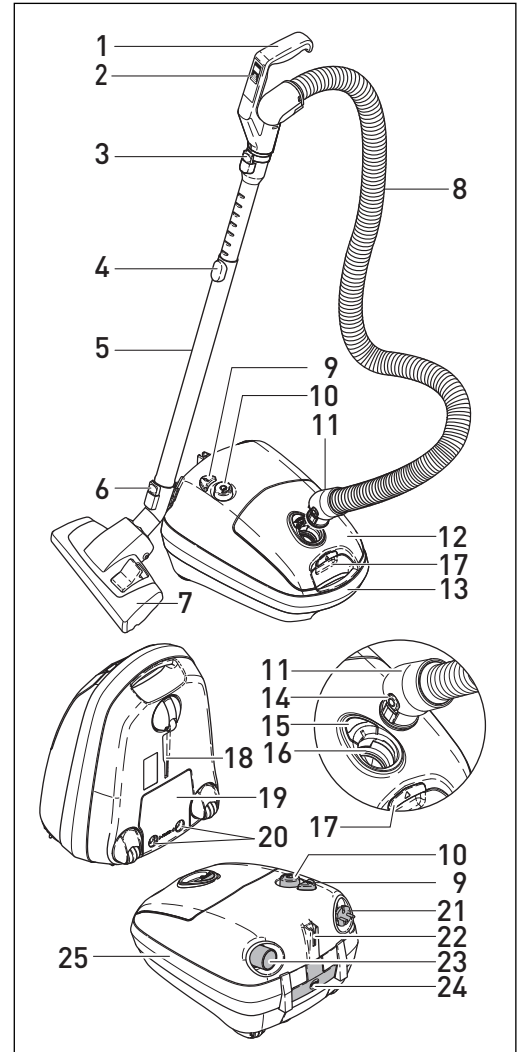

# ASSEMBLY

Push the neck (11) of the hose (8) into the suction opening of the canister (16).

**E3:** The three notches in the suction opening (32) will line up with the three prongs on the neck. When the notches are lined up correctly, the neck will snap firmly into place.

**E1 & E2:** The slot in the suction opening (31) will line up with the raised bar on the hose neck. When lined up correctly, the neck will snap firmly into place.

To release the hose from the suction opening, press release buttons (14) on the neck of the hose (11), and pull the neck out.

Connect the handle (1) to the top of the telescopic tube (5). Snap in place. To release the telescopic tube (5) from the handle, push the handle release button (3) and slide the handle out.

Attach the head or brush to the bottom of the telescopic tube (5). Insert the bottom of the telescopic tube into the neck (33) of the head or brush until it locks into place; or line up the square hole in the telescopic tube with the notches in the front of the neck, and snap firmly into place. To release a head or brush from the telescopic tube (5), push the release button (6), and pull the head or brush tool off the end of the telescopic tube. The release button (6) is in the same position on all of the heads, brushes and power heads.

To attach the dusting brush clip (26) - **E3:** locate the two raised ridges on the upper end of the telescopic tube (5) just below the handle. Push the clip onto the tube directly below the ridges then slide the clip up until it locks onto the ridges. **E1 & E2:** Push the clip onto the tube and slide to desired position.

Snap the dusting brush (27) into the holder.

**NOTE: To attach the ET-1 power head to your E3 Premium, please refer to your power head owner's manual for instructions. Attaching incorrectly could cause damage.**

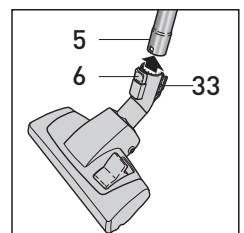
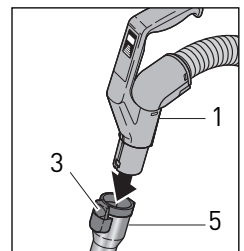
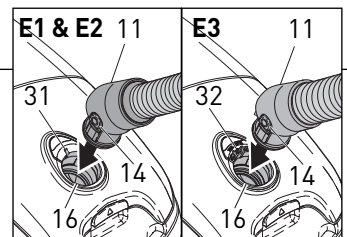

**NOTE:** All illustrations shown in this manual represent the E3 model except where part numbers and instructions are different for each model.

# OPERATING INSTRUCTIONS ALL AIRBELT E VACUUMS

## Starting The Machine - Figures 1, 2 & 3

Before turning on your canister, make sure that you have a firm hold on the handle grip to keep the machine from moving forward.

1. With the canister main power control knob (10) in the OFF position, grasp the plug and pull the power cord (21) out from the power cable recess (figure 1). The power cord (21) should be unwound from the cable reel at least two thirds of its length. **Note:** do not over-extend the cord.
2. Plug the polarized power cord into a 120 volt wall outlet located near the floor.
3. Press the main power knob on the base of the canister (10) gently with your foot or hand. A blue light will illuminate indicating that the power is on.

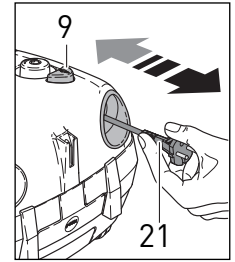

Figure 1

## Suction Control - Figure 3

**E1 Kombi & E2 Turbo users:** the suction control dial is located on the top side of the canister on the power control knob (10). Rotate the dial clockwise for maximum suction. Rotate counter-clockwise to reduce suction for vacuuming curtains or delicate fabrics.

**E3 Premium users:** The suction control slider (2) is located on the handle. For information on suction control, refer to page 9 of this manual.

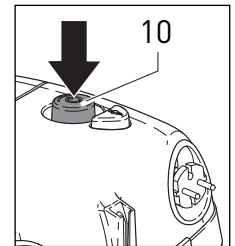

Figure 2

## Operating the Machine - Figures 1, 4, 5, 6, 7 & 8

Adjust the telescopic tube (5) to the correct height by pushing the slide button (4, figure 4) and gently pulling the tube out to lengthen, or pushing it in to shorten. Release the slide button (4) to lock the tube to the adjusted height.

When changing heads, always switch the vacuum off with the power control knob (10), and then unplug the power cord.

The "bag full or clog" indicator (15, figure 5) works correctly only at full power. At lower power levels, the "bag full or clog" indicator may show incorrectly. Check the status of the filter bag regularly at full power. If the indicator remains orange at full power and the filter bag is not full, check for clogs (see page 13).

To retract the cord, switch the vacuum off, unplug it from the outlet, then push the power cable rewind button (9, figure 1) and the mechanism will automatically rewind. Before rewinding the cable, always switch off and unplug the vacuum. Hold the plug while rewinding the cord onto the cord reel. Avoid letting the plug whip while rewinding.

The vacuum can be stored with the canister in a horizontal or vertical position (figures 6, 7 & 8). The Parquet brush, Kombi nozzle and Turbo nozzle have a parking tab located on the front of the neck (34). Insert the parking tab into the upper side of the parking groove (18 or 22) and slide down firmly. For vertical storage, or for easy carrying, use the parking groove on the underside (18). For horizontal storage, use the parking groove on the end of the canister (22).

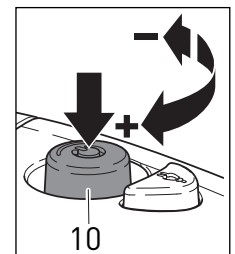

Figure 3 - E1 & E2

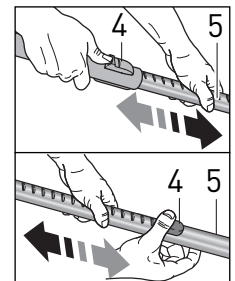

Figure 4

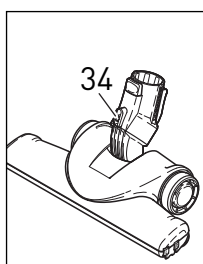

Figure 6

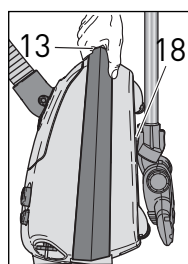

Figure 7

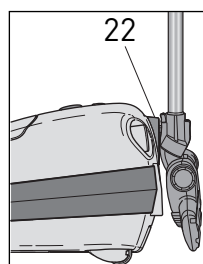

Figure 8

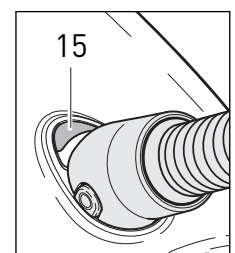

Figure 5



## WARNING!

The quality, condition, coating, texture, age and manufacturing technique of all floor surfaces vary. Therefore, vacuums with rotating brushes, including your SEBO, may damage some floor coverings or surfaces. Some types of high-gloss hardwood floors, cushion vinyl, berber carpets, long shag, and delicate or hand-woven carpets are particularly vulnerable to damage by rotating brushes. When possible, consult the materials supplied by your flooring manufacturer for information on proper upkeep and cleaning. **To ensure that your new SEBO vacuum cleaner is compatible with your floor, please test the vacuum cleaner on each type of flooring surface in a small inconspicuous area to determine if any damage occurs. If damage occurs, stop using the vacuum cleaner immediately!**



# ADDITIONAL OPERATING INSTRUCTIONS FOR E3 WITH POWER HEAD

Please refer to your ET-1 power head owner's manual for more information

## Starting The E3 Premium and Suction Control - Figures 1, 2, 9 & 10

Before turning on your canister, make sure that the vacuum handle is in its upright locked position (figure 9).

1. With the canister main power control knob (10) in the OFF position, and the power control slider on the handle (2, figure 10) in the OFF position, pull the power cord out from the base of the canister (figure 1). The power cord should be unwound from the cable reel at least two thirds of its length.

**Note:** do not over-extend the cord.

2. Plug the polarized power cord into a 120 volt wall outlet located near the floor.
3. Press the main power control knob (10) on the base of the canister gently with your foot or hand. The blue light will illuminate indicating that the power is on (figure 2).
4. Slide the Power Control Slider (2, figure 10) toward the MAX position. It will move freely between 0 suction and MAX suction. Set the slider to the suction desired.

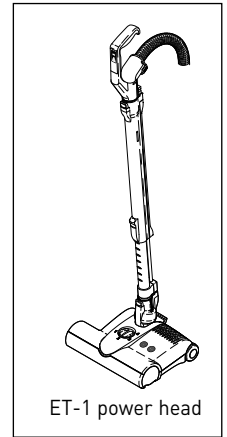

Figure 9

## Operating The E3 Premium - Figures 1, 11 & 12

When the power head is on with the handle in the upright locked position (see figure 9), the brush roller will not spin.

To release the ET-1 power head from the upright locked position, press down on the foot pedal, (35, figure 11) lower the handle into the normal operating position and push the button on the top of the power head (36, figure 12) to engage the brush roller. The green light on the power head will illuminate.

The handle can be lowered to a horizontal position useful for vacuuming under beds.

You may adjust the suction control with the power control slider (2) as you vacuum different surfaces or when using the accessory tools. For optimal cleaning and brushing, operate the machine at the maximum suction power setting and push the power head slowly over the carpet.

When the canister's main power control knob is in the ON position, you may turn the power head off and on with the power control slider (2). To turn the power head off using the power control slider, pull the slider to 0 suction, then continue pulling the slider up until it "clicks" into the OFF position. The green power head light will then shut off (the blue light on the canister (10) will remain illuminated until the vacuum is powered off using the main power control knob).

**Always turn the power off on both the canister and the power head when changing heads or unplugging the vacuum.** Slide the power control slider on the handle to its OFF position, press the power control knob on the base of the canister (10) gently with your foot or hand, then unplug the canister to completely shut down the power when changing heads or storing the vacuum.

To retract the cord, switch the vacuum off, unplug it from the outlet, then then push the power cable rewind button (9, figure 1) and the mechanism will automatically rewind. Before rewinding the cable, always switch off and unplug the vacuum. Hold the plug while rewinding the cord onto the cord reel. Avoid letting the plug whip while rewinding.

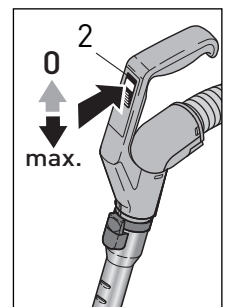

Figure 10

0 = Zero Suction  
MAX = Maximum Suction

ON position -  
Move the slider toward MAX.

OFF position -  
Pull the slider up to 0 suction  
then continue pulling the  
slider up until it "clicks" into  
the OFF position.

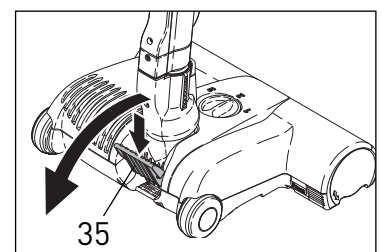

Figure 11

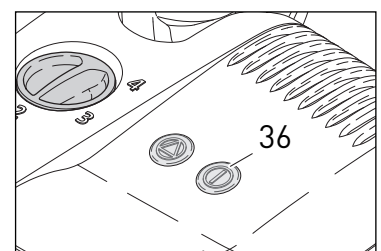

Figure 12

## Using the Telescopic Tube, Hose & Attachments - Figures 13, 14, 15 & 16

The telescopic tube (5) is useful for vacuuming corners and hard-to-reach areas. You may use the telescopic tube without a brush, power head or attachment. To remove a brush or power head, switch off the power control knob (10) and unplug the vacuum. Then, press the tool release button (6) and pull the tube out of the head. The crevice nozzle (23) and upholstery nozzle (24) are stored on the bottom of the canister (figure 14). The crevice nozzle, dusting brush (27) and upholstery nozzle may be inserted onto the end of the tube. It is not necessary to turn off the vacuum while switching the **standard** attachments (the crevice nozzle, upholstery nozzle or dusting brush). After use, switch off the power, unplug the vacuum and remove attachment. Re-insert the telescopic tube into the power head or brush, turning the tube if needed, until you hear it click into place.

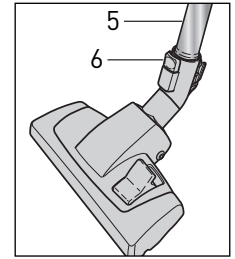

Figure 13

**NOTE! E3 users with ET-1 power head, please refer to your power head user's manual for more detailed instructions for connecting your power head.**

To use the hose without the telescopic tube, switch off the power and unplug the vacuum. Push the handle release button (3) and pull the HANDLE out of the end of the telescopic tube. Do not try to separate the hose from the handle! Insert the crevice nozzle (23), dusting brush (27) or upholstery nozzle (24) onto the end of the handle (figure 15). You may also connect a head to the handle (figure 16). After use, switch off the power, unplug the vacuum and remove the attachment. Re-insert the handle into the telescopic tube making sure it is seated correctly and snap it into place.

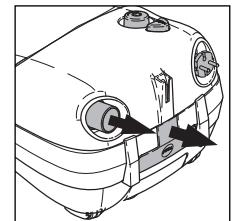
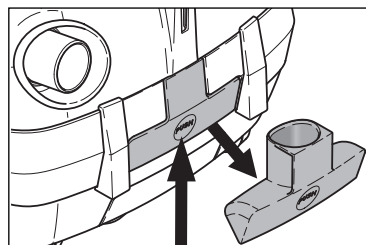

Figure 14



Push button to release upholstery nozzle.

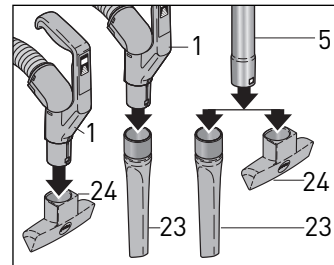

Figure 15

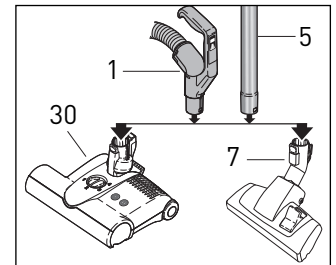

Figure 16

## USE AND MAINTENANCE OF BRUSHES AND HEADS

**⚠ Always unplug vacuum from outlet before dismantling any part of machine!**

To remove a brush or power head, switch off the power and unplug the vacuum. Then, press the tool release button (6) and pull the tube out.

**NOTE! E3 users with the ET-1 power head, please refer to your power head user's manual for more detailed instructions for operating and maintaining your power head.**

### Parquet Brush - Figure 17

The Parquet brush (28) is specially designed for use on hard surfaces. It is lightweight with soft bristles, so it glides gently over floors and provides easy maneuverability. Fibers and hair can be pulled out of the bristles manually, or vacuum the bristles with the telescopic tube.

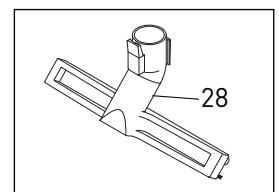

Figure 17

### Kombi Nozzle - Figure 18

The Kombi nozzle (7) is adjustable for carpet or hard floors. To set for carpet, push the small end of the toggle button (37) downward until it clicks into place. The hard floor dusting brush will raise up allowing the head to move over the carpet. To set for hard floors, push the large end of the toggle button (37) downward until it clicks into place. The brush will lower to gently sweep your floors. **The toggle button in Figure 18 is set in the position for hard floors.** The brush should be cleaned regularly. Remove the Kombi nozzle from the telescopic tube to clean. Fibers and hair can be pulled out of the bristles manually, or vacuum the bristles with the telescopic tube. The brush strip is removable for cleaning and replacement.

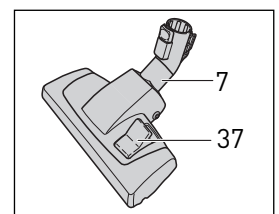

Figure 18

### Turbo Nozzle - Figure 19

The Turbo nozzle (29) has an air-driven rotating brush for gentle brushing of carpets. The Turbo nozzle can be adjusted for high and low pile carpet. To adjust the head for high pile carpet, push the slider button (39) to the right. For low pile carpet, push the slider button (39) to the left. **The slider in Figure 19 is set in the low pile position.** The rotating brush should be cleaned regularly. Remove the Turbo nozzle from the telescopic tube to clean. Remove fibers and hair from the brush manually.

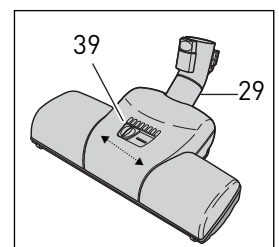



Figure 19

# VACUUM MAINTENANCE

 **Always unplug vacuum from outlet before dismantling any part of machine!**

## Changing the Filter Bag - Figures 20, 21 & 22

To change the filter bag (40), lift the filter bag release catch (17, figure 20) then lift open the filter bag cover (12). Seal the used filter bag with the sealing cap (41). Tilt the green sealing plate collar up (42, figure 21) and lift the bag out. Slide the front of the sealing plate (42) of a new bag vertically into the bag holder (43, figure 22). Line up the sealing plate so that the U-shaped metal spring (44) is positioned in the slot (44) of the collar and tilt it back into place. Close the cover, making sure it snaps shut completely. The cover will not close if the bag is inserted improperly. Do not re-use the filter bags. **Note:** the nature of the contents of the filter bag will affect the point at which it needs changing. Fine dust may require an earlier change even though the bag is not full. Fluff or hair allows air to pass through easily, so the filter bag may overfill before the “bag full” indicator turns orange.

The “bag full or clog” indicator works correctly only at full power. At lower power levels, the “bag full or clog” indicator may read incorrectly. Check the status of the filter bag regularly at full power.

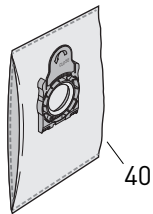

Filter Bags  
Part #8300AM

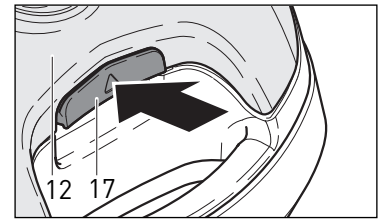

Figure 20

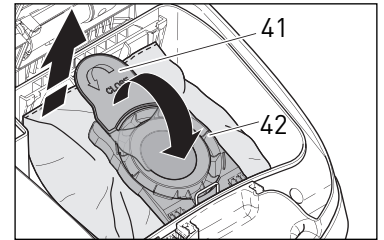

Figure 21

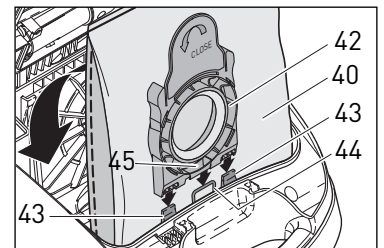
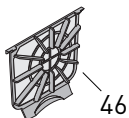

Figure 22

## Changing the Pre-motor Filter - Figure 23

The pre-motor filter (46) needs to be changed when it becomes extremely dirty or clogged with dust, or after approximately 10 to 20 filter bags have been used. To change the pre-motor filter, lift the filter bag release catch (17, figure 20), lift open the filter bag cover (12) and remove the filter bag. Grasp the tab at the bottom of the filter (47, figure 23) and pull the filter out and up. When the filter is horizontal, lift it out of the holder (48). Insert the new filter into the holder horizontally (48) then swing it downward until the the tab (47) locks into place. Replace the filter bag and the filter bag cover.



Pre-motor Filter  
part of the E Filter Set  
Part #8322AM

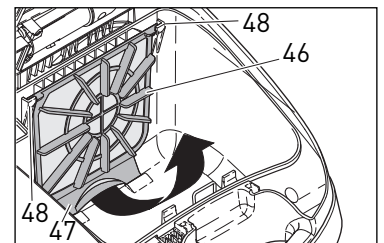

Figure 23

## Changing the Exhaust Microfilter - Figures 24, 25 & 26

After 10 to 20 bags have been used, change the exhaust microfilter (49). To remove the exhaust microfilter, press the filter cover release buttons together (20, figure 24) and pull the filter cover (19) off. Pull the material part of the filter out of the machine (49, figure 25). Press the red latches (50, figure 26) located on either side of the filter inward and pull the filter out. Insert the opening of the new filter over the exhaust opening with the red alignment tab at the bottom. When it is aligned, push down until the red latches (50) click shut to hold the filter in place. Tuck the material part of the filter inside the opening. Insert the cover by fitting the tabs on the top side of the cover into the grooves. Push the cover closed, making sure it snaps shut completely.



Exhaust Microfilter  
part of the E Filter Set  
Part #8322AM

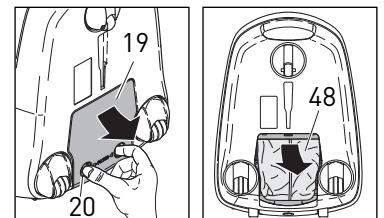

Figure 24

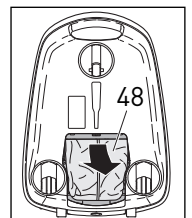

Figure 25

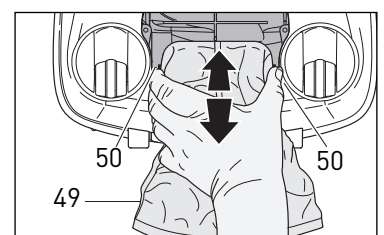

Figure 26

**Note:** Never operate the vacuum with incorrectly attached filters or without filters, bag, AIRBELT or filter bag housing cover (26). Do not re-use filter bags. Do not wash and re-use filters.

## Changing the AIRBELT - Figures 27-33

Your E-Series vacuum cleaner is fitted with the patented AIRBELT shock absorber system, which protects your walls and furniture and filters exhaust air. The AIRBELT shock absorber system consists of the foam bumper (52) and the AIRBELT fabric cover (25). If damage occurs to the AIRBELT cover, it will need to be replaced.

To remove the AIRBELT system (25 & 52), remove the upholstery nozzle from the rear of the machine (figure 27), and lever out the nozzle holder (51) using a slot-head screwdriver (figure 28). The AIRBELT system (25 & 52) can then be pried out of the recess with a screwdriver (figure 29) and removed by carefully sliding the assembly toward the front of the machine (figure 30). Remove the damaged cloth cover (25) from the foam bumper (52).

Fit the new AIRBELT cloth cover (25) over the foam bumper (52) by inserting the side rails (53, figure 31) of the cloth cover (25) into the grooves (54) of the foam bumper. The upper side rail of the cloth cover has a mark (55, figure 31). Insert the upper side rail with the mark into the groove which is marked "TOP" (56, figure 31). Start from one end and continue fitting the cloth into the grooves around the bumper (figure 32). Fit the bumper assembly to the front of the machine, then press in around the sides toward the rear (figure 33).

Refit the upholstery nozzle holder (51) under the parking groove (22) and tilt it down to lock it into the lower side. Finally, re-insert the upholstery nozzle.

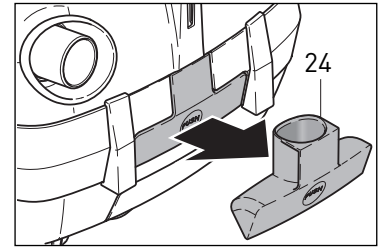

Figure 27

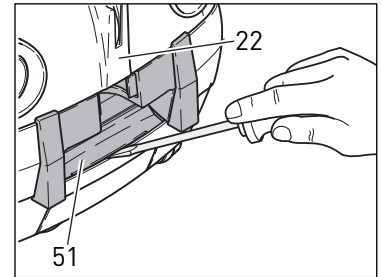

Figure 28

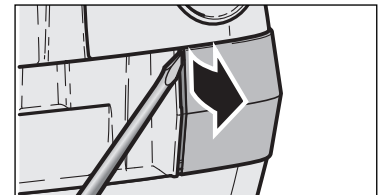
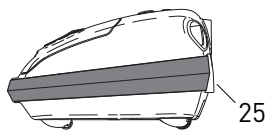

Figure 29



AIRBELT Cover  
E1 Kombi, E2 Turbo, E3 Arctic White and Red: Part #8221AM01  
E3 Black: Part #8221AM07

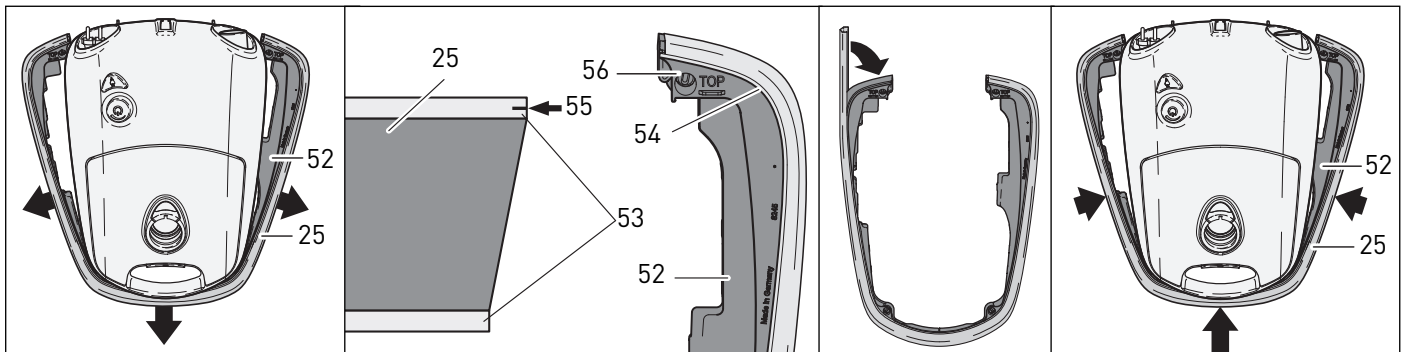

Figure 30

Figure 31

Figure 32

Figure 33

**Note:** Never operate the vacuum with incorrectly attached filters or without filters, bag, AIRBELT or filter bag housing cover (12). Do not re-use filter bags. Do not wash and re-use filters.

# CLOG REMOVAL



**Always unplug vacuum from outlet before removing any clogs!**

**NOTE!** E3 users with ET-1 power heads, please refer to your power head user's manual for more detailed instructions for removing clogs in your power head.

If the "bag full or clog" warning indicator (15) remains orange after the filter bag has been changed and the filters are in good condition, there is likely a clog in the system.

## Clogs in the Head or Brush - Figure 34

Clogs in the swivel neck (56) of a head or brush can be cleared by first pressing the tool release button (6) and removing the brush or head. Check inside the swivel neck channel, and clean out pathway.

## Clogs in the Telescopic Tube - Figure 34

Remove head from telescopic tube (5) by pushing the tool release button (6) and pulling the tube out. Remove the hose from the top of the telescopic tube by pushing the handle release button (3). A stiff wire or stick can be used to push the clog out of the tube.

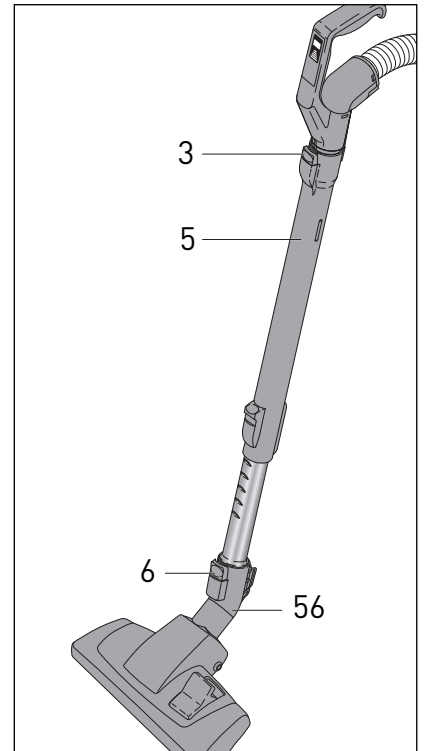

Figure 34

## Clogs in the Hose - Figures 35, 36 & 37

Check for suction at the handle end of the hose. If you feel reduced suction, the blockage is in the hose. To clear blockages in the hose (8), remove the handle (1) from the telescopic tube by pressing the handle release button (3). Hold the hose upright with one hand blocking the end of the handle (figure 36) and switch on the machine at full power. If necessary, quickly lift your hand on and off the end of the hose.

**Note:** Do not insert a wire or stick into the hose. Doing so may cause damage to the hose.

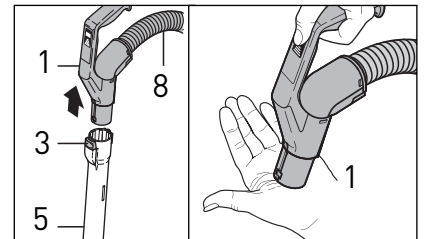

Figure 35

Figure 36

## Clogs in Entrance to Filter Bag - Figures 38 & 39

Remove hose (10) from vacuum cleaner. To release the hose from the suction opening, press release buttons (14) on the neck of the hose (11), and pull the neck out. Check the hose neck (11) and suction opening (16) for clogs. If the clog is in the filter bag opening, open the filter bag cover and clean out the entrance to the bag (57).

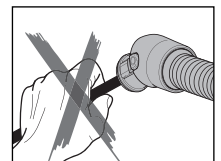

Figure 37

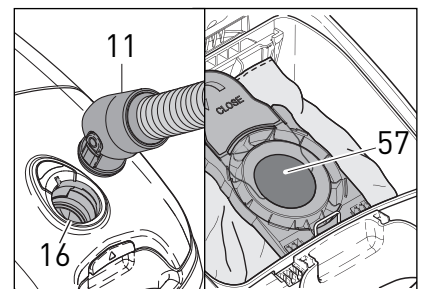

Figure 38

Figure 39

# TROUBLE-SHOOTING GUIDE



**Always unplug vacuum from outlet before dismantling any part of the machine!**

<b>PROBLEM</b>	<b>REASON</b>	<b>SOLUTION</b>
<b>Does not turn on</b>	1. Telescopic tube not inserted properly.	1. See page 7.
	2. Not plugged into working outlet.	2. Use another outlet.
	3. Cable worn.	3. Replace cable.
	4. Hose neck (11) not inserted properly into suction opening (16).	4. See Assembly on page 7.
	5. E3: The power control slider switch is set to "0" ("off" position).	5. E3: Set slider switch to "on" position. See page 9.
<b>Bag full or clog light on Bag full or clog light on &amp; machine shuts off</b>	1. Bag full.	1. Replace filter bag. See page 11.
	2. Clog in hose, telescopic tube, brush or head, or entrance to filter bag.	2. See Clog Removal on page 13. E3 users with clog in power head attachment: refer to clog removal in the ET-1 owner 's manual.
	3. Exhaust microfilter dirty.	3. Replace exhaust microfilter. See page 11.
	4. Pre-motor filter dirty.	4. Replace filter. See page 11.
<b>Does not pick up</b>	1. Hose/handle assembly not correctly inserted.	1. Re-insert hose/handle assembly making sure that it is lined up properly and is snapped into place. See page 7.
	2. The suction control dial is rotated to no suction setting	2. E1 & E2: Rotate suction control clockwise for suction. See page 8.
	3. Filter bag cover not closed.	3. See below.
<b>Filter bag door won't fully close</b>	1. Filter bag cover not fully closed.	1. Re-insert bag. Lock the cover down firmly.
	2. Bag not inserted properly	2. Re-insert bag. Lock the cover down firmly.
	3. Pre-motor filter not properly inserted.	3. Remove the filter bag and make sure the pre-motor filter is seated firmly in place (see pg. 11, figure 23).

# AIRBELT E1 KOMBI AND E2 TURBO SCHEMATIC AND PARTS LIST

#91602AM E1 Kombi - Arctic White  
 #91620AM E2 Turbo - Dark Blue

## Canister with Handle/Hose

### 91602AM E1 Kombi - Arctic White Machine

Pos.	Part #	Description
1	8335WEER	Bottom casing, white
2	8275GSER	Castor front, gray-black
3	8276GSER	Castor rear, gray-black
4	8249WEER	Exhaust filter cover, white
5	8230GSER	Technic module incl. pos. 6+7
6	7045ER	Bag holder
7	8053ER	Bolt 20 x 5/7
8	8212ER	Engine mount gasket
9	8349ER	Vac motor 120V
10	8282ULER	Wire
11	8045ER	Motor support
12	8220ER	Noise limiting cover
13	8289ER	Motor cover
14	665631ER	Cable rewind unit, AM plug
15	8256ER	Potentiometer pinion
16	8338ER	On/Off button E1, cpl.
17	8291ER	Printed circuit board
18	01036ER	Screw 4 x 14
19	01017ER	Screw STS 4 x 20 T20
20	8322AM	Microfilter box E - pre-motor filter and exhaust microfilter
21	8300AM	Filter bags E
22	8328WEER	Top casing, white
23	8340ER	Top cover E1, inner part
24	8224WEE1ER	Filter cover
25	8237ER	Bumper
26	8221AM01	AIRBELT, gray-black
27	8213GSER	Support
28	8066GS	Crevice nozzle
29	8310GS	Upholstery nozzle
30	8310	Hose cpl. incl. handle
31	8314	Hose E1
32	6300GS	Handle grip, cpl.
33	6303GS	Retaining ring
34	6237ER	Telescopic tube
35	1736GS	Fitting neck
36	1735ER	Release button, cpl.
37	6238ER	Locking mechanism
38	6425ER	Sliding knob
50	1397GS	Kombi nozzle, grey-black
53	6728ER	Dusting brush & clip

### 91620AM E2 Turbo - Dark Blue Machine

Pos.	Part #	Description
1	8335DBER	Bottom casing, dark blue
4	8249DBER	Cover exhaust air filter, dark blue
22	8328DBER	Top casing, dark blue
24	8224DBE2ER	Filter cover
51	6780GS	Turbo nozzle TT-C
52	6391DA	Parquet brush

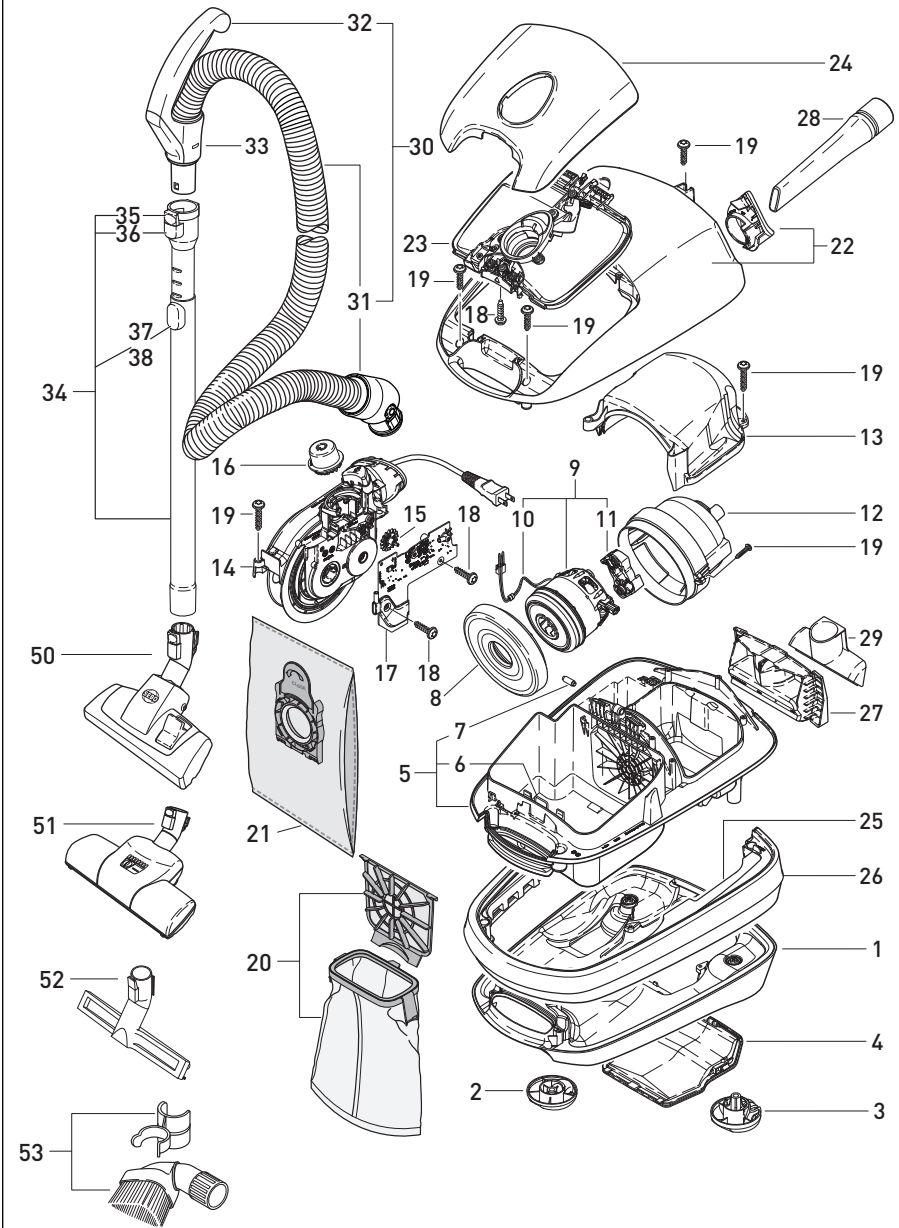

Kombi Nozzle  
standard with E1 Kombi



Turbo Nozzle  
standard with E2 Turbo



Parquet Brush  
standard with E2 Turbo

# AIRBELT E3 PREMIUM SCHEMATIC AND PARTS LIST

#91641AM E3 Premium - Arctic White  
 #91642AM E3 Premium - Red  
 #91643AM E3 Premium - Graphite

## Canister with Handle/Hose

### 91640AM E3 Premium - Arctic White Machine

Pos.	Part #	Description
1	8335WEER	Bottom casing, white
2	8275GGER	Castor front, gray-black
3	8276GGER	Castor rear, gray-black
4	8249WEER	Cover exhaust air filter, white
5	8230GGER	Technic module incl. Pos. 6+7
6	7045ER	Bag holder
7	8053ER	Bolt 20 x 5/7
8	8212ER	Engine mount gasket
9	8243ER	Vac motor 120V
10	8282ULER	Wire
11	8045ER	Motor support
12	8220ER	Noise limiting cover
13	8289ER	Motor cover
14	665633ER	Cable rewind unit, AM plug
16	8339ER	On/Off button E3, cpl.
17	8296ER	Printed circuit board
18	01036ER	Screw 4 x 14
19	01017ER	Screw STS 4 x 20-T20
20	8322AM	Filter box E - pre-motor filter and exhaust microfilter
21	8300AM	Filter bags E
22	8328WEER	Top casing, white
23	8341ER	Top cover E3, inner part
24	8224WEPRER	Filter cover
25	8237ER	Bumper
26	8221AM01	AIRBELT, gray-black
27	8213GGER	Support
28	8066GS	Crevice nozzle
29	8210GS	Upholstery nozzle
31	6391DA	Parquet brush.
32	6728ER	Dusting brush & clip
33	8312	Hose E3 incl. handle
37	6270GS	Telescopic tube
38	6420GS	Release button cpl.
39	8320ER	Cabling set
40	6369G1	Mains cable

### 91642AM E3 Premium - Red Machine

1	8335DRER	Bottom casing, red
4	8249DRER	Cover exhaust air filter, red
22	8328DRER	Top casing, red
24	8224DRPRER	Filter cover
26	8221AM01	AIRBELT, gray-black

### 91643AM E3 Premium - Graphite Machine

1	8335GGER	Bottom casing, gray black
4	8249GGER	Cover exhaust air filter, gray black
22	8328GGER	Top casing, gray black
24	8224GSPR	Filter cover
26	8221AM10	AIRBELT, stripes

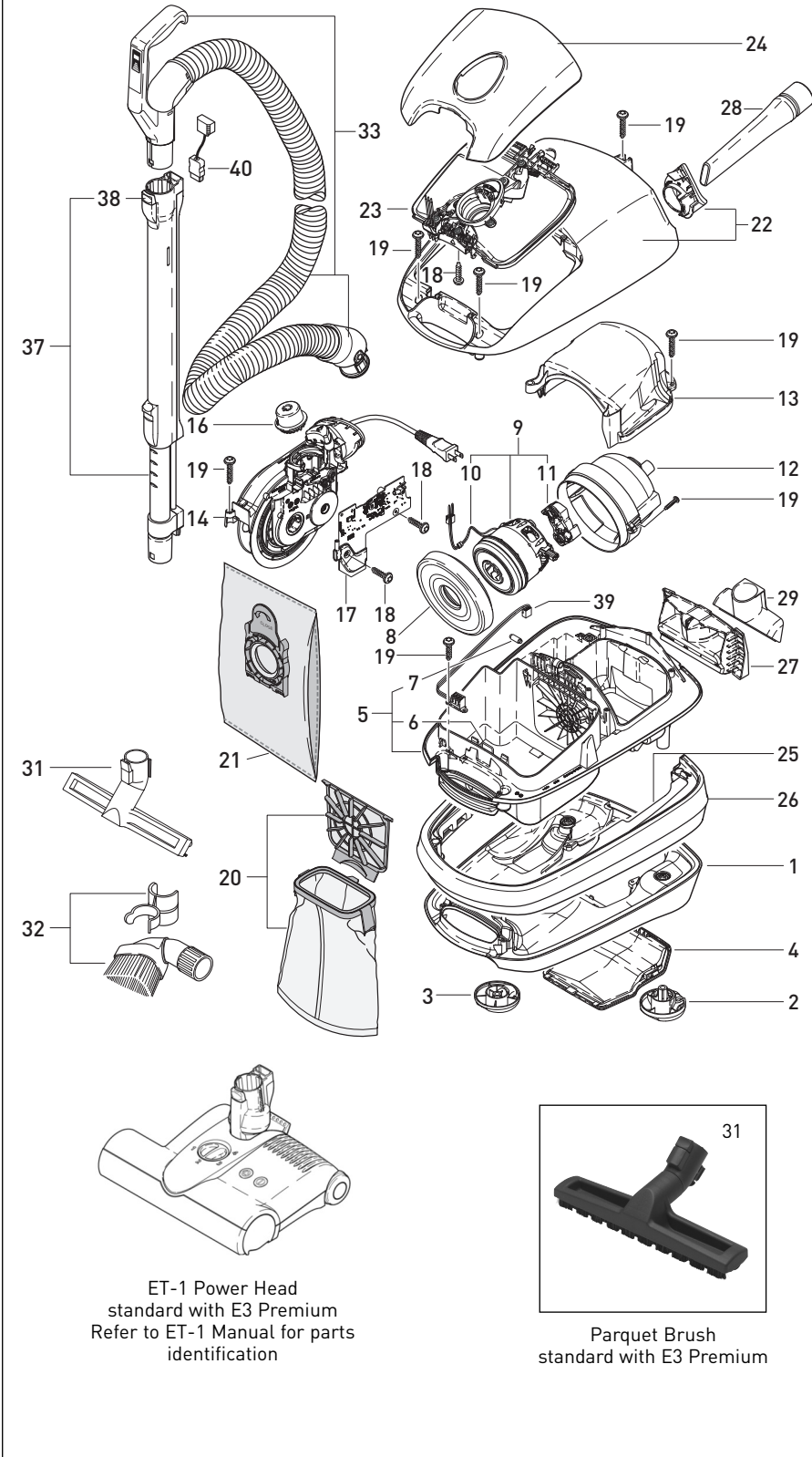

ET-1 Power Head  
 standard with E3 Premium  
 Refer to ET-1 Manual for parts  
 identification

Parquet Brush  
 standard with E3 Premium